

form-scaff

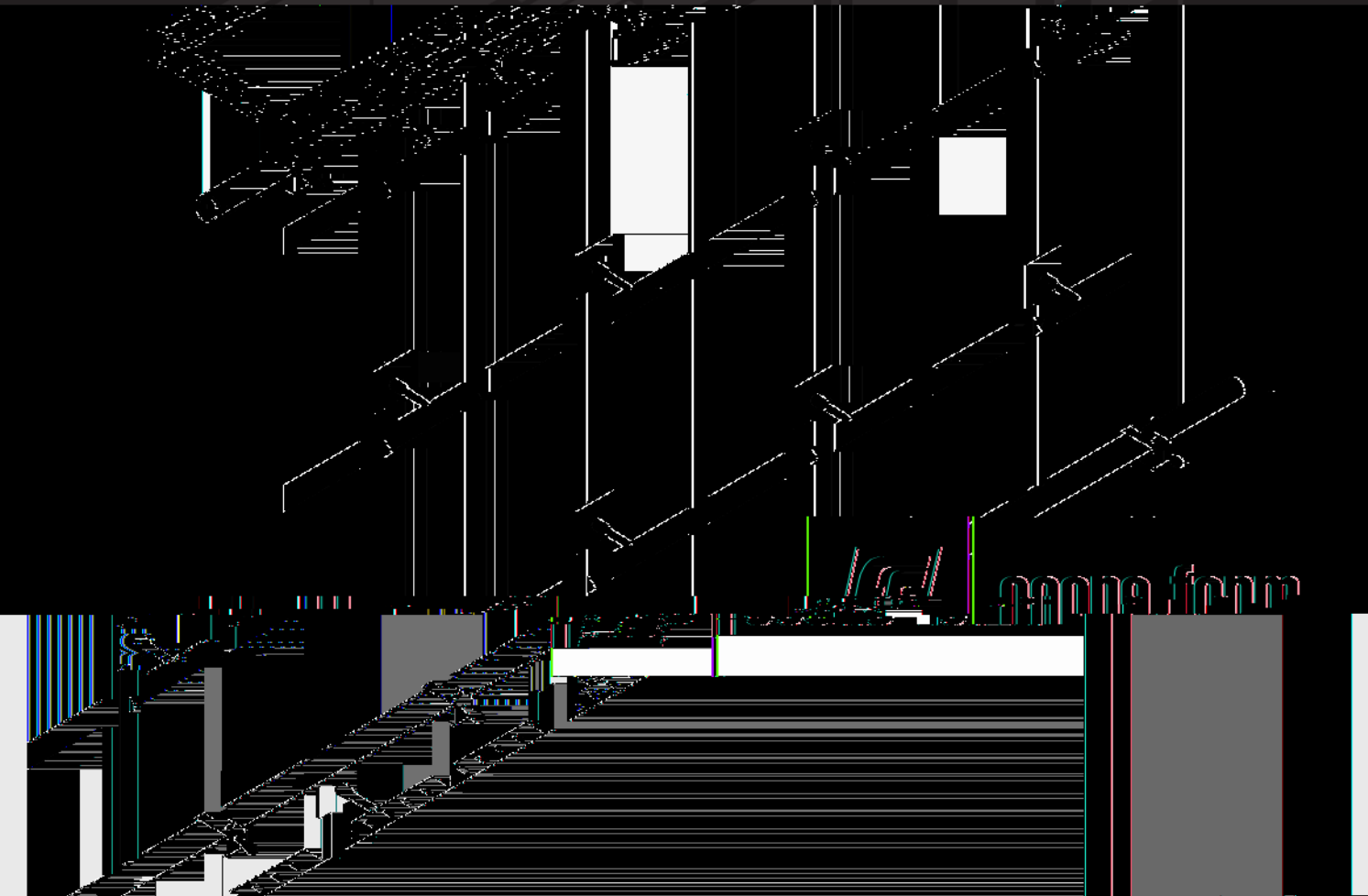

st. Katalog 2010

Produkt

www.form-scaff.com



With branches nationwide, Form-Scaff is the largest scaffolding and formwork sales, hire and distribution network in South Africa. As part of the WACO Africa organisation, Form-Scaff is 100% South African owned. Innovation driven, the company's range of products and systems are recognised as the industry benchmark. The company provides end-to-end industry solutions from design development, training, technical support and on-site contracting.

The Waco International group employs over four thousand people world-wide and has operations in Africa, the UK, Australia, New Zealand and Chile.

Econo-Form today is almost as popular as 3 decades ago. This simple yet versatile forming system has proven its ability to form almost any shape or size:

- Bases & Foundations
- Columns
- Walls
- Beams
- Slabs



Disclaimer:

Copyright in this catalogue vests in Form-Scaff, a division of Waco Africa (Proprietary) Limited ("Form-Scaff") and extends inter alia, to the making of copies in whole or in part without the prior written consent of Form-Scaff.

While every effort has been made to ensure the accuracy of the information in this catalogue, we cannot accept responsibility for any errors which may occur as a result of reliance on the contents of this catalogue and are not liable for any loss of any nature that may be incurred as a result of such reliance. Details of any of the products may change without prior notice.

The customer must ensure that 'good practice' is adopted on site by competent persons and that the products shown in this catalogue are erected, used and stripped in accordance with the relevant Codes of Practice and the OHS Act and Regulations 95 of 1993. This catalogue does not contain any design detail but lists and depicts the items available under this product range. The responsibility for design is the responsibility of the customer.

Note: The colours used in this document are for illustrative purposes only and may differ on actual products.

Contents



Econo-Form Slabs

- Page 02** System Features
- Page 04** Panels
- Page 05** Channels & Fillers
- Page 06** Tube & Fittings
- Page 08** Corners
- Page 10** Flex-Forms
- Page 11** Ties - Ferrule Type
- Page 12** Ties - Form Type
- Page 13** Ties - Dywidag Type

Econo-Form Walls

- Page 14** Ties - Water-Bar Type
- Page 15** Ties - Coil Type
- Page 18** Climbing
- Page 22** Lifting
- Page 23** Fixing

Contact Details

- Page 25** Head Office & Branches





econo-form



Econo-Form

Form-Scaff has been manufacturing and supplying the Econo-Form system to contractors for over 40 years. The system has proven itself to be a versatile formwork solution that can be used to form vertical, inclined, horizontal and curved concrete surfaces.

System Features

- Quick and easy to assemble and strip.
- Individual components are lightweight and easy to man handle.
- Soldiers and walers may be attached to provide large gang-formed units.
- Tie holes at a 300mm spacing allows alternative tie locations.
- The punched periphery provides abundant locations for attachments.
- A large variety of panel shapes and sizes are available.

General Assembly

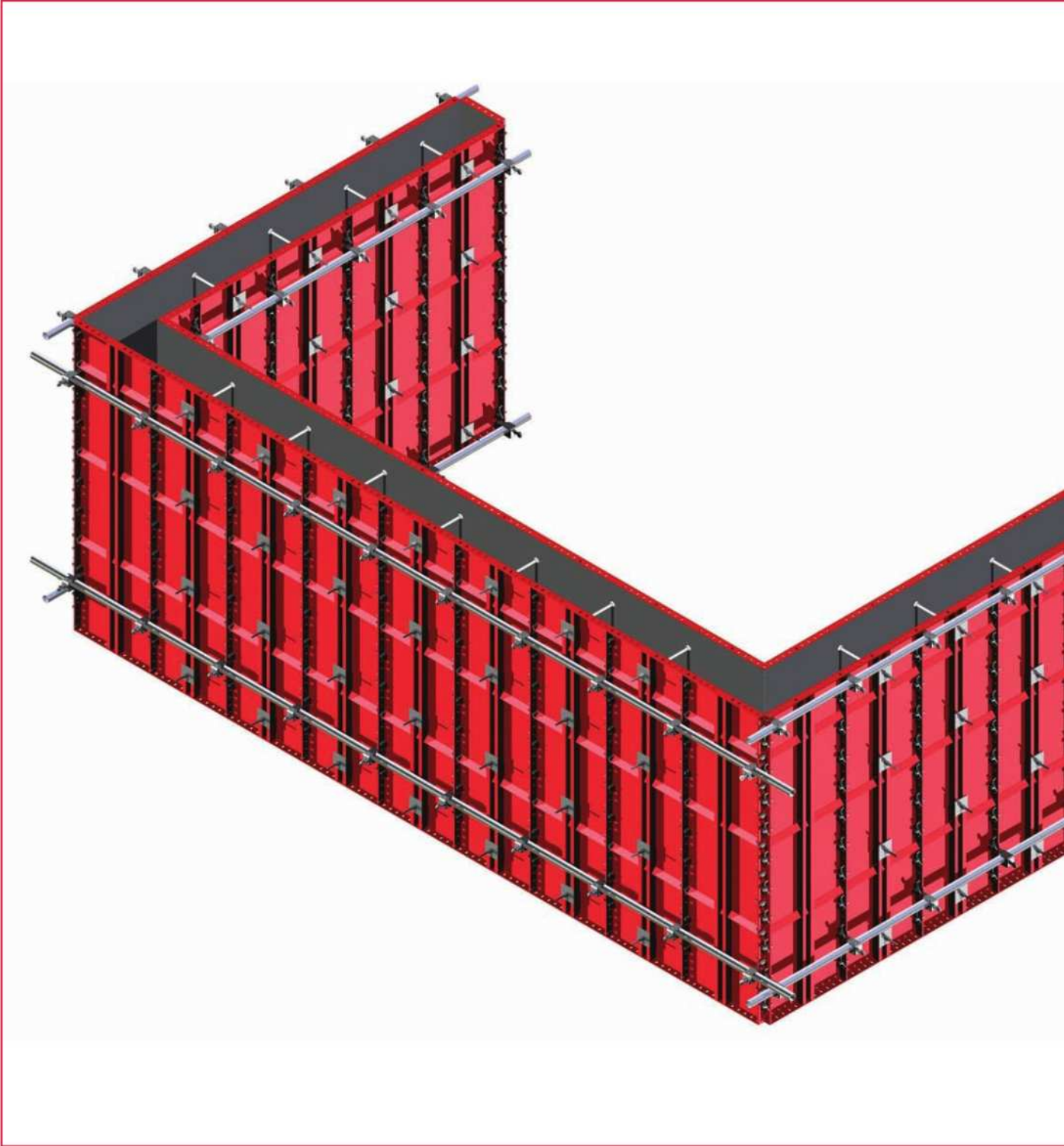

Econo-Form Panels

Econo-Form Panels are fabricated with a 3mm steel faceplate with punched slotted holes at 50mm centres in the periphery. 18mm Tie holes are at 300mm centres along the centreline of the panel.

CODE	DESCRIPTION	MASS(kg)
2705001	ECONO-FORM PANEL 3000 X 600	78.85
2705003	ECONO-FORM PANEL 3000 X 450	65.83
2705005	ECONO-FORM PANEL 3000 X 300	46.41
2705101	ECONO-FORM PANEL 3000 X 230	38.58
2705007	ECONO-FORM PANEL 3000 X 150	29.08
2705008	ECONO-FORM PANEL 2700 X 600	70.56
2705010	ECONO-FORM PANEL 2700 X 450	58.95
2705012	ECONO-FORM PANEL 2700 X 300	41.88
2705102	ECONO-FORM PANEL 2700 X 230	34.82
2705014	ECONO-FORM PANEL 2700 X 150	26.23
2705015	ECONO-FORM PANEL 2400 X 600	63.54
2705017	ECONO-FORM PANEL 2400 X 450	53.01
2705019	ECONO-FORM PANEL 2400 X 300	37.36
2705103	ECONO-FORM PANEL 2400 X 230	31.04
2705021	ECONO-FORM PANEL 2400 X 150	23.38
2705022	ECONO-FORM PANEL 2100 X 600	55.28
2705024	ECONO-FORM PANEL 2100 X 450	46.15
2705026	ECONO-FORM PANEL 2100 X 300	32.84
2705104	ECONO-FORM PANEL 2100 X 230	27.29
2705028	ECONO-FORM PANEL 2100 X 150	20.53
2705029	ECONO-FORM PANEL 1800 X 600	48.26
2705031	ECONO-FORM PANEL 1800 X 450	40.22
2705033	ECONO-FORM PANEL 1800 X 300	28.31
2705105	ECONO-FORM PANEL 1800 X 230	23.51
2705035	ECONO-FORM PANEL 1800 X 150	17.69
2705036	ECONO-FORM PANEL 1500 X 600	39.98
2705038	ECONO-FORM PANEL 1500 X 450	33.33
2705040	ECONO-FORM PANEL 1500 X 300	23.79
2705106	ECONO-FORM PANEL 1500 X 230	19.75
2705042	ECONO-FORM PANEL 1500 X 150	14.84
2705043	ECONO-FORM PANEL 1200 X 600	32.94
2705045	ECONO-FORM PANEL 1200 X 450	27.37
2705047	ECONO-FORM PANEL 1200 X 300	19.26
2705107	ECONO-FORM PANEL 1200 X 230	15.97
2705049	ECONO-FORM PANEL 1200 X 150	11.98
2705050	ECONO-FORM PANEL 900 X 600	25.91
2705052	ECONO-FORM PANEL 900 X 450	21.44
2705054	ECONO-FORM PANEL 900 X 300	14.74
2705108	ECONO-FORM PANEL 900 X 230	12.23
2705056	ECONO-FORM PANEL 900 X 150	9.14

Note: Other sizes available upon request.

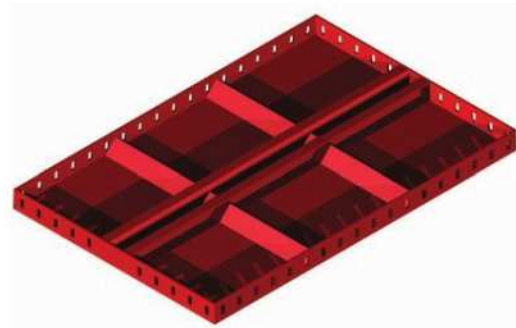

Plastic Button

Plastic Buttons are used to plug any unused tie holes.

CODE	DESCRIPTION	MASS(kg)
2960810	BUTTON 25mm DIA	0.01
2960808	BUTTON 21mm DIA	0.01
2960811	BUTTON 18mm DIA	0.01
2960809	BUTTON 16mm DIA	0.01



Econo-Form Channels

Econo-Form Channels can either be used as small panels or as light soldiers to tie through when using the Flex-Form Panels.

CODE	DESCRIPTION	MASS(kg)
2706141	ECONO-FORM CHANNEL 3000 X 100	18.78
2706142	ECONO-FORM CHANNEL 3000 X 75	16.60
2706143	ECONO-FORM CHANNEL 2700 X 100	16.96
2706144	ECONO-FORM CHANNEL 2700 X 75	14.97
2706145	ECONO-FORM CHANNEL 2400 X 100	15.10
2706146	ECONO-FORM CHANNEL 2400 X 75	13.34
2706147	ECONO-FORM CHANNEL 2100 X 100	13.26
2706148	ECONO-FORM CHANNEL 2100 X 75	11.72
2706149	ECONO-FORM CHANNEL 1800 X 100	11.44
2706150	ECONO-FORM CHANNEL 1800 X 75	10.07
2706151	ECONO-FORM CHANNEL 1500 X 100	9.56
2706152	ECONO-FORM CHANNEL 1500 X 75	8.44
2706153	ECONO-FORM CHANNEL 1200 X 100	7.75
2706154	ECONO-FORM CHANNEL 1200 X 75	6.82
2706155	ECONO-FORM CHANNEL 900 X 100	5.93
2706156	ECONO-FORM CHANNEL 900 X 75	5.19

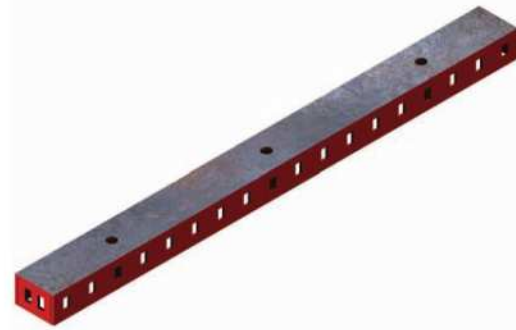

Filler Panels

The Econo-Form Filler facilitates the closing of gaps of up to 180mm between panels. It is simply placed between the two adjacent panels and fixed with B or C Clamps to the water behind.

CODE	DESCRIPTION	MASS(kg)
2711511	ECONO-FORM FILLER PANEL 3000 X 200	15.83
2711512	ECONO-FORM FILLER PANEL 2700 X 200	14.33
2711513	ECONO-FORM FILLER PANEL 2400 X 200	12.66
2711514	ECONO-FORM FILLER PANEL 2100 X 200	11.08
2711515	ECONO-FORM FILLER PANEL 1800 X 200	9.50
2711516	ECONO-FORM FILLER PANEL 1500 X 200	7.99
2711517	ECONO-FORM FILLER PANEL 1200 X 200	6.38
2711518	ECONO-FORM FILLER PANEL 900 X 200	4.78



Tifa Ef-Ti Panels

Ef-Ti Panels are used to join Econo-Form Panels to Tifa / Tifa-Lite Panels.

CODE	DESCRIPTION	MASS(kg)
5110122	TIFA EF-TI PANEL 2700	28.83
5110121	TIFA EF-TI PANEL 1200	13.08
5110120	TIFA EF-TI PANEL 900	10.14



Tube & Fittings

Wedge Sets

Wedge sets are used to join two Econo-Form Panels or Flex-Form Panels together.



CODE	DESCRIPTION	MASS(kg)
2715555	KEY (HD)	0.09
2715556	WEDGE CURVED (HD)	0.10
2715552	WEDGE BENT CLIP	0.06
2715553	WEDGE STRAIGHT (HD)	0.09



CODE	DESCRIPTION	MASS(kg)
2715555	KEY (HD)	0.09
2715556	WEDGE CURVED (HD)	0.10
2715552	WEDGE BENT CLIP	0.06
2715553	WEDGE STRAIGHT (HD)	0.09
2715554	WEDGE STRAIGHT (LD)	0.06
2715551	WEDGE BENT CLIP (LD)	0.04

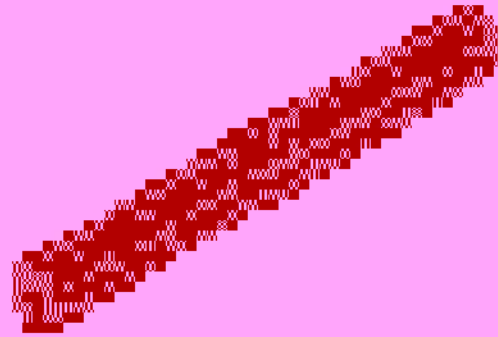

CODE	DESCRIPTION	MASS(kg)
2715555	KEY (HD)	0.09
2715556	WEDGE CURVED (HD)	0.10
2715552	WEDGE BENT CLIP	0.06
2715553	WEDGE STRAIGHT (HD)	0.09
2715554	WEDGE STRAIGHT (LD)	0.06
2715551	WEDGE BENT CLIP (LD)	0.04

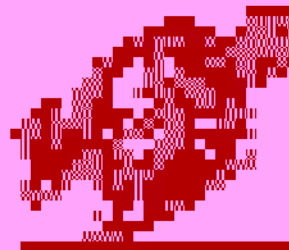

CODE	DESCRIPTION	MASS(kg)
2715555	KEY (HD)	0.09
2715556	WEDGE CURVED (HD)	0.10
2715552	WEDGE BENT CLIP	0.06
2715553	WEDGE STRAIGHT (HD)	0.09
2715554	WEDGE STRAIGHT (LD)	0.06
2715551	WEDGE BENT CLIP (LD)	0.04



Application - Fittings

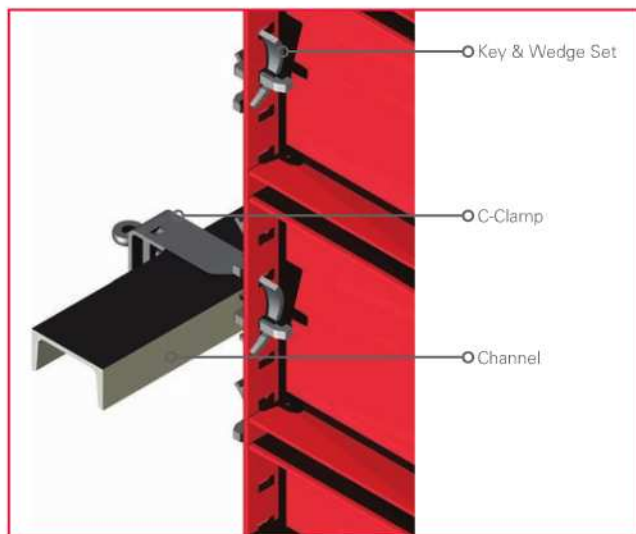

External Corner Angles

External Corner Angles are used to align and secure standard panels on outside corners at a 90° angle.

CODE	DESCRIPTION	MASS(kg)
2720608	EXT CRN ANGLE 3000 X 50 X 50 X 5	11.31
2720607	EXT CRN ANGLE 2700 X 50 X 50 X 5	10.18
2720606	EXT CRN ANGLE 2400 X 50 X 50 X 5	9.05
2720605	EXT CRN ANGLE 2100 X 50 X 50 X 5	7.92
2720604	EXT CRN ANGLE 1800 X 50 X 50 X 5	6.79
2720603	EXT CRN ANGLE 1500 X 50 X 50 X 5	5.66
2720602	EXT CRN ANGLE 1200 X 50 X 50 X 5	4.52
2720601	EXT CRN ANGLE 900 X 50 X 50 X 5	3.39
2720611	EXT CRN ANGLE 600 X 50 X 50 X 5	2.26

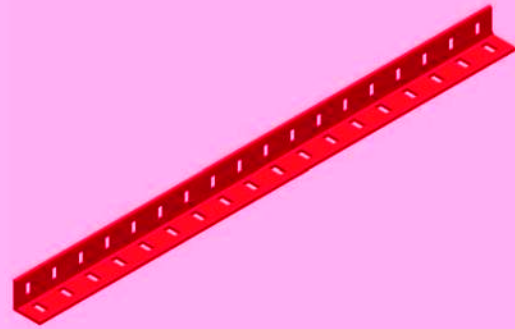

Internal Corner Panels

Internal Corner Panels are used to align and secure standard panels on inside corners at a 90° angle.

CODE	DESCRIPTION	MASS(kg)
2707205	INT CNR PANEL 3000 X 150 X 150	39.07
2707210	INT CNR PANEL 2700 X 150 X 150	35.26
2707215	INT CNR PANEL 2400 X 150 X 150	31.08
2707220	INT CNR PANEL 2100 X 150 X 150	28.55
2707225	INT CNR PANEL 1800 X 150 X 150	24.98
2707230	INT CNR PANEL 1500 X 150 X 150	23.23
2707235	INT CNR PANEL 1200 X 150 X 150	16.21
2707240	INT CNR PANEL 900 X 150 X 150	12.40



Internal & External Splay Panels

Splay panels are used to connect Econo-Form Panels together at an angle of 135°.

CODE	DESCRIPTION	MASS(kg)
3375730	EXTERNAL SPLAY 1200 X 200 X 100	15.09
3375731	EXTERNAL SPLAY 900 X 200 X 100	11.60
3370728	INTERNAL SPLAY 3000 X 200 X 100	38.00
3370725	INTERNAL SPLAY 1200 X 200 X 100	15.09
3370726	INTERNAL SPLAY 900 X 200 X 100	11.60



Application - Corners

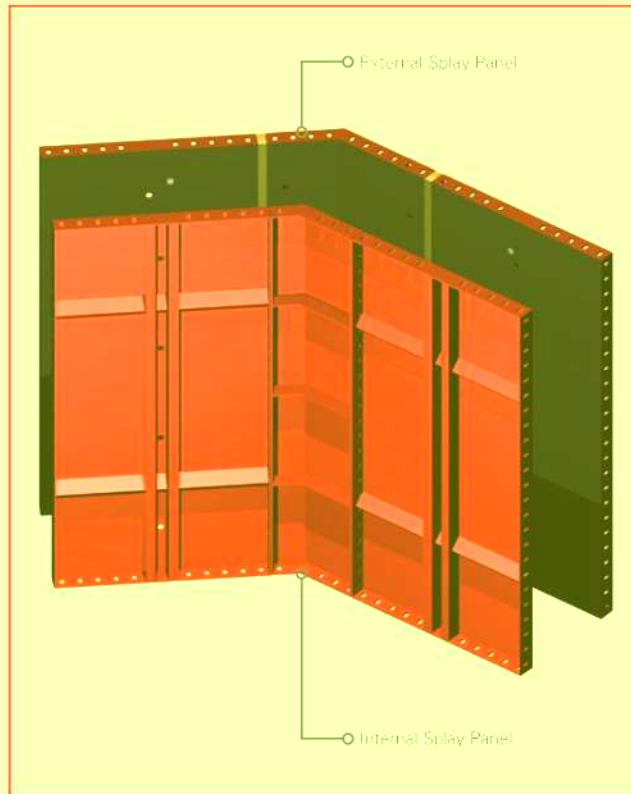
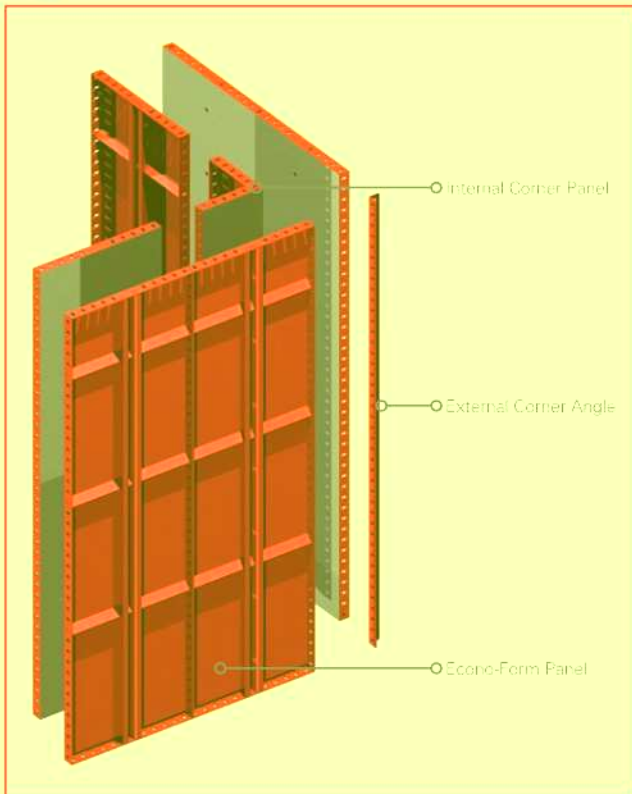

Wall-Form Flex-Form Panels

Flex-Form Panels are used to create curved or radiused concrete walls or beams. They are held in shape by radiused scaffold tubes with ties installed through Econo-Form Channels adjacent to the Flex-Form Panels.

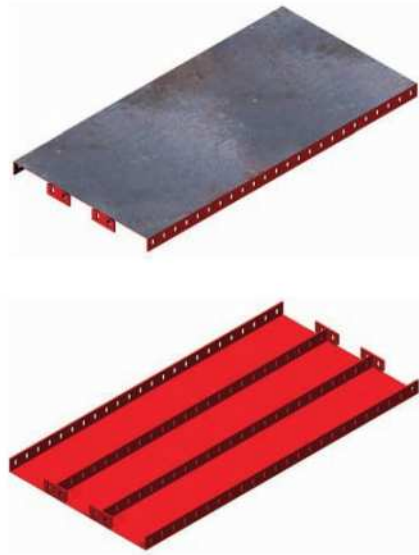

CODE	DESCRIPTION	MASS(kg)
3355001	WALLFORM FLEXFORM 2000 X 600	33.84
3355002	WALLFORM FLEXFORM 2000 X 500	26.83
3355004	WALLFORM FLEXFORM 1800 X 600	30.52
3355005	WALLFORM FLEXFORM 1800 X 450	22.72
3355006	WALLFORM FLEXFORM 1800 X 300	18.38
3355707	WALLFORM FLEXFORM 1500 X 600	25.54
3355708	WALLFORM FLEXFORM 1500 X 450	18.99
3355701	WALLFORM FLEXFORM 1200 X 600	21.16
3355702	WALLFORM FLEXFORM 1200 X 450	15.73
3355704	WALLFORM FLEXFORM 900 X 600	16.02
3355705	WALLFORM FLEXFORM 900 X 450	11.87
3355706	WALLFORM FLEXFORM 900 X 300	9.70

Application - Circular Walls

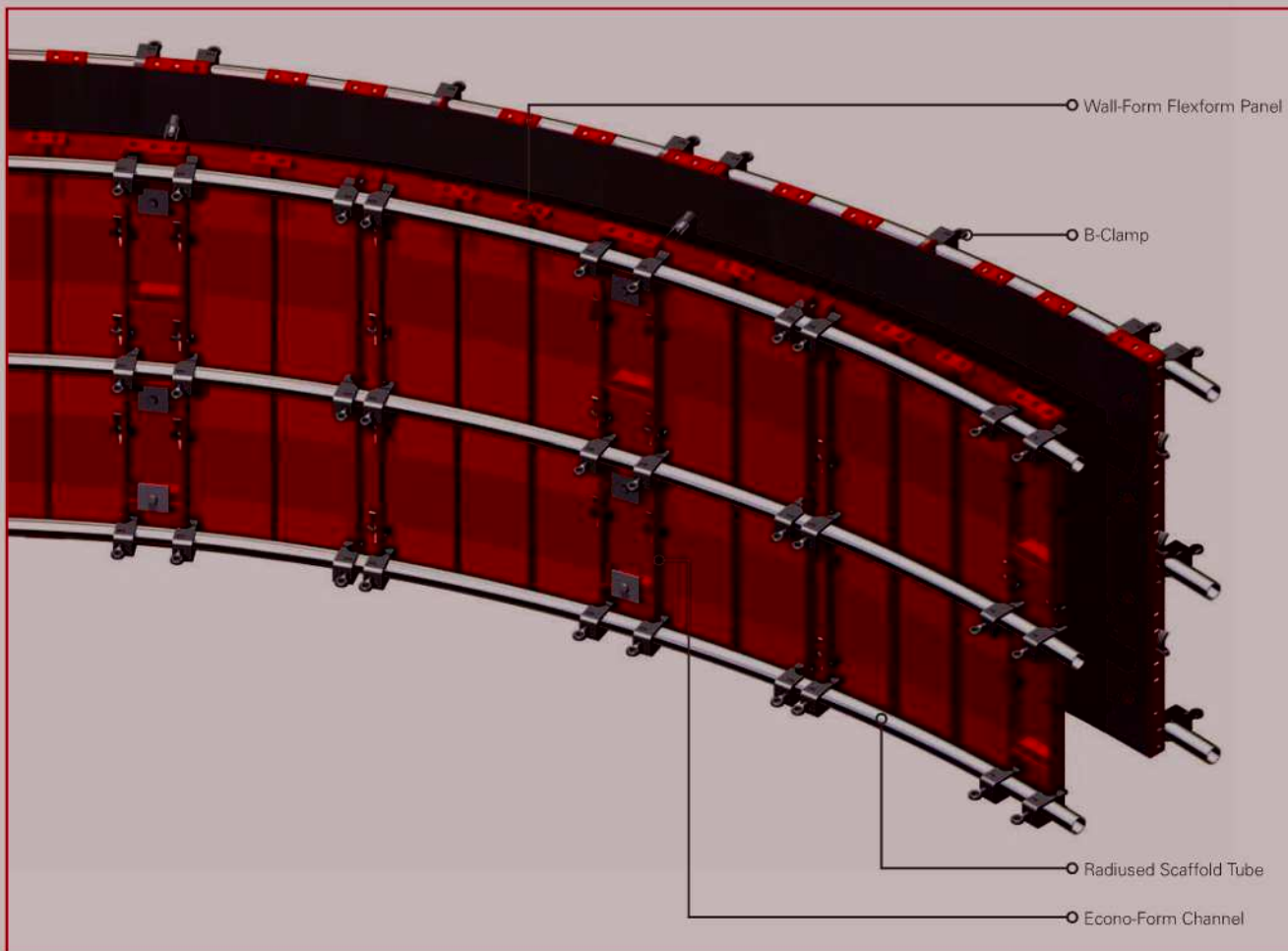

PVC Ferrule Tube

PVC Ferrule Tubes are used with any recoverable tie system. The tie is fed through the PVC Tube that stays behind in the concrete.

CODE	DESCRIPTION	MASS(kg)
5405083	PVC FERRULE TUBE 24 ID & 27 OD	0.04
2960806	PVC FERRULE TUBE 22 ID & 25 OD	0.04
2960805	PVC FERRULE TUBE 17 ID & 19 OD	0.04



PVC Ferrule Tube Cone

The PVC Ferrule Tube Cone is placed on either end of the PVC Ferrule Tube and is removed after the concrete has been poured. The hole can then be plugged if necessary.

CODE	DESCRIPTION	MASS(kg)
5405084	PVC FERRULE TUBE CONE 24 OD	0.01
2960813	PVC FERRULE TUBE CONE 22 OD	0.01
2960815	PVC FERRULE TUBE CONE 17 OD	0.01



Ferrule Rose

Ferrule Roses are used when steel round bars or reinforcing bars are used for the tie. The Ferrule Rose is secured to the steel tie by tightening the grubscrew.

CODE	DESCRIPTION	MASS(kg)
2960803	FERRULE ROSE 12DIA (C/W GRUB)	0.40
2960804	FERRULE JACK	2.60



Application - Ferrule Ties

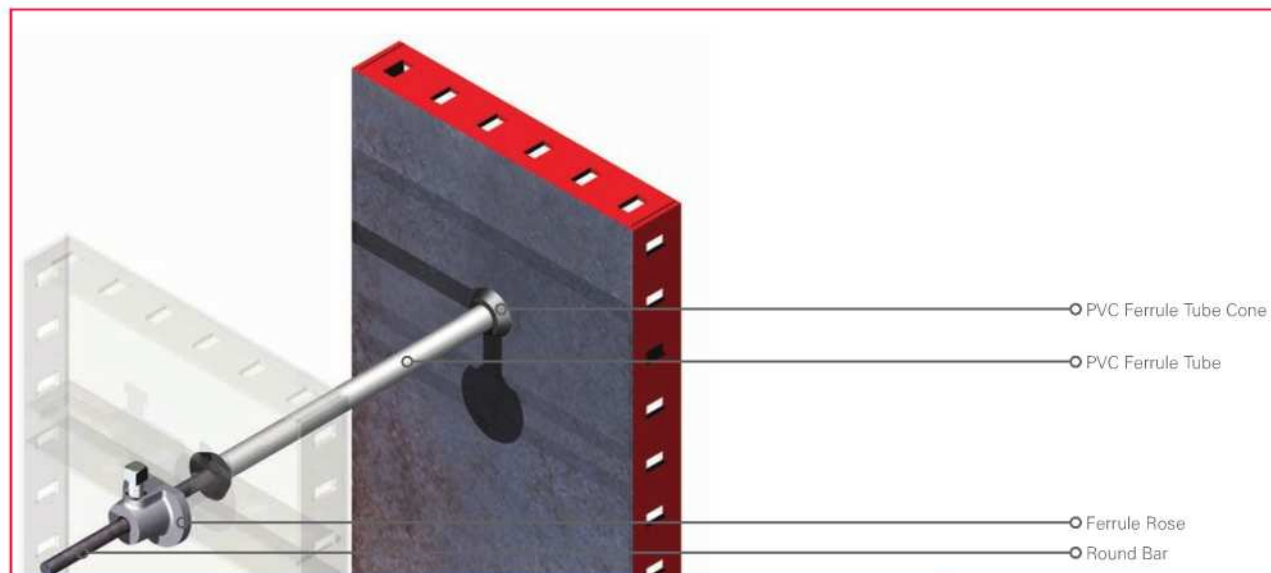

Ties - Form Type

Form-Tie Bar

Form-Ties are recoverable ties used through tie sleeves.

CODE	DESCRIPTION	MASS(kg)
5405070	FORM-TIE BAR F20 (PER M)	2.47
5405061	FORM-TIE BAR F16 (PER M)	1.58
5405072	FORM-TIE BAR F12 (PER M)	0.76



Form-Tie Nut

Form-Tie Nuts are used each end of the Form-Tie.

CODE	DESCRIPTION	MASS(kg)
5405071	FORM-TIE NUT F20	0.49
5405062	FORM-TIE NUT F16	0.22
5405073	FORM-TIE NUT F12	0.15



Form-Tie Pad

The Form Pad acts as a washer between the Form-Tie Nut and the Panel.

CODE	DESCRIPTION	MASS(kg)
5405063	FORM-TIE PAD FOR F20 FORM TIE	1.50
5405064	FORM-TIE PAD FOR F16 FORM TIE	1.20

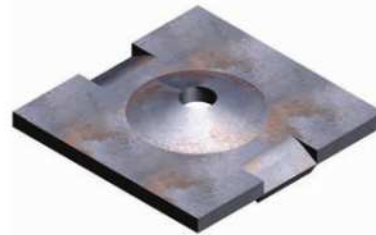

Application - Form-Ties

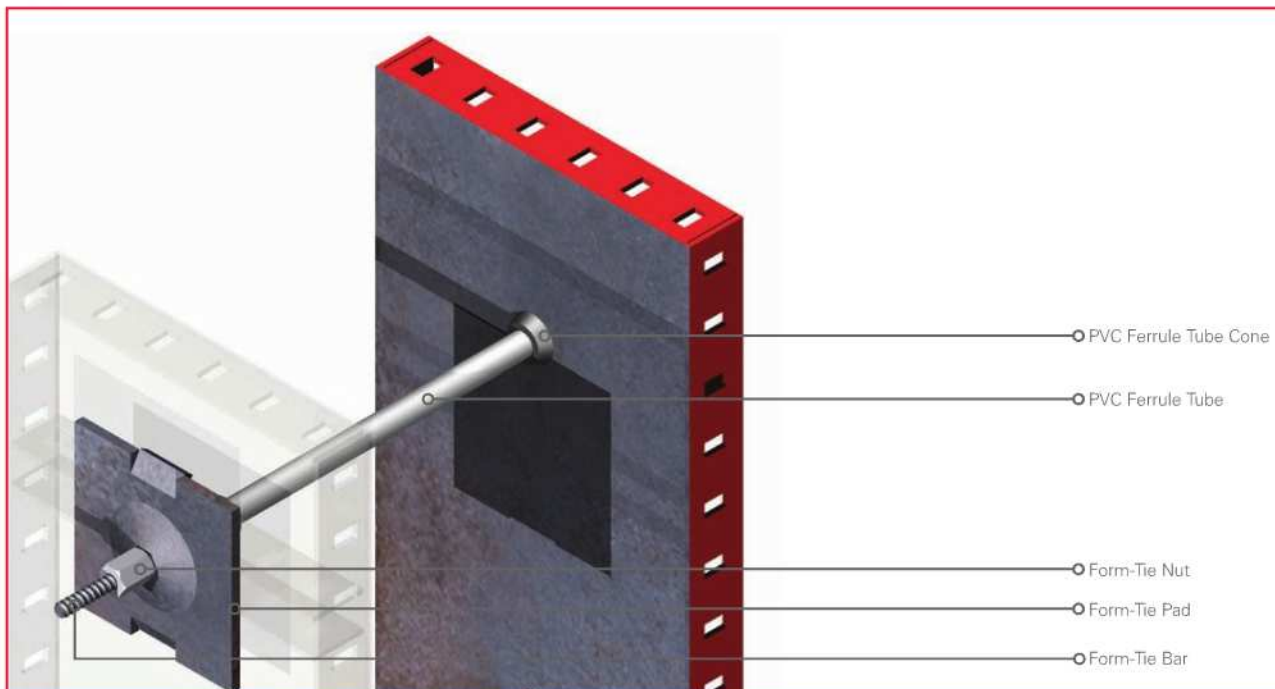

Dywidag Tie Bar

Dywidag Ties are recoverable ties used through tie sleeves.

CODE	DESCRIPTION	MASS(kg)
5405077	DYWIDAG BAR 15mm 500	0.7
5405078	DYWIDAG BAR 15mm 1000	1.5
5405079	DYWIDAG BAR 15mm 1500	2.2
5405085	DYWIDAG BAR 15mm 2000	2.9
5405086	DYWIDAG BAR 15mm 2500	3.6
5405087	DYWIDAG BAR 15mm 3000	4.3
5405088	DYWIDAG BAR 15mm 3500	5.1
5405089	DYWIDAG BAR 15mm 4000	5.8
5405092	DYWIDAG BAR 15mm 4500	6.5
5405093	DYWIDAG BAR 15mm 5000	7.2
5405094	DYWIDAG BAR 15mm 5500	8.0
5405095	DYWIDAG BAR 15mm 6000	8.7



Dywidag Nuts

The Dywidag Combi Nut or Wing Nut & Washer combination can be used with the 15mm Dywidag Bar.

CODE	DESCRIPTION	MASS(kg)
5110032	DYWIDAG WING NUT	1.8
5110035	WASHER 100 X 100 X 6	0.5
5110150	DYWIDAG COMBI NUT	1.2



Application - Dywidag Ties

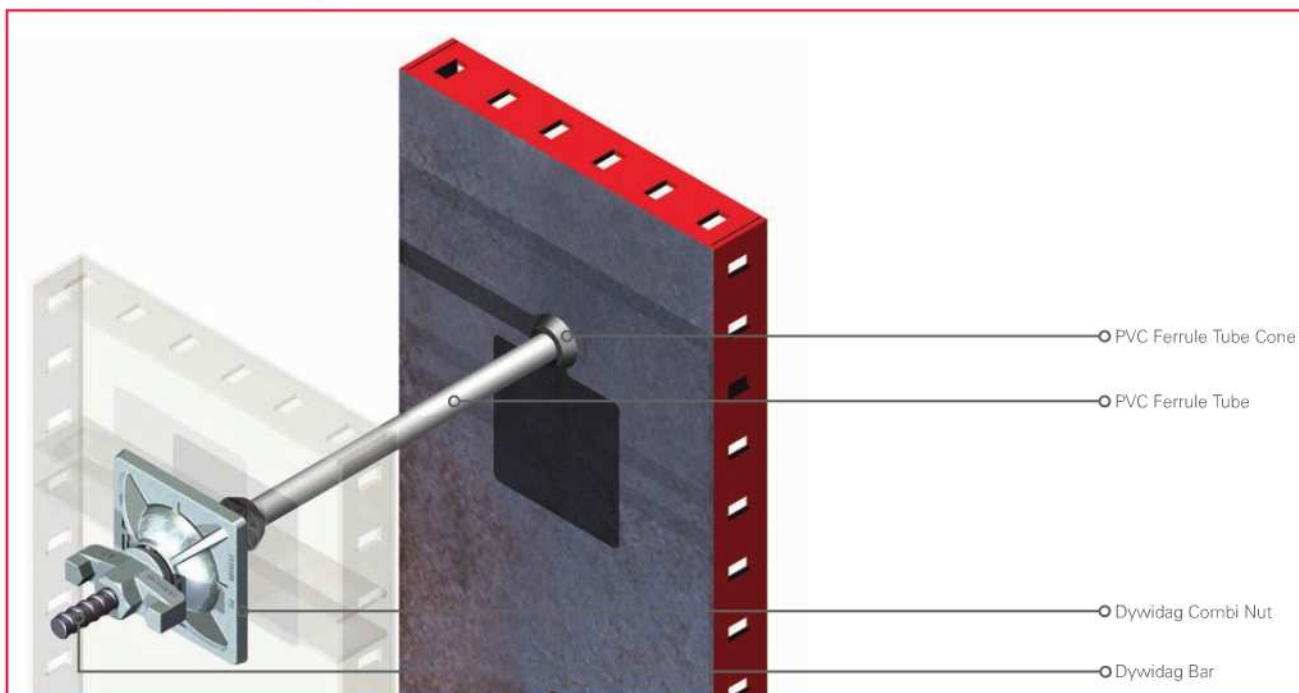

Ties - Water-Bar Type

Water-Bar Casting

The Water-Bar Casting stays behind in the concrete. The 15mm Dywidag Bars are removed with the Dywidag Bar Spanner.

CODE	DESCRIPTION	MASS(kg)
5821100	WATER-BAR CASTING	1.00



Cones & Bolts

Steel Cones are used with non-recoverable ties. The threaded bar stays behind and the steel cone is recovered by means of an extractor tool.

CODE	DESCRIPTION	MASS(kg)
5410013	STEEL CONE M24 / F16	0.69
5410050	STEEL CONE M24 / DYWIDAG 15mm	0.73
5410051	STEEL CONE M24 / M24	0.81
2966028	SET SCREW M24 X 75	0.03



Extractor Tools

Are used to remove the Steel Cones and Dywidag Bars from the concrete.

CODE	DESCRIPTION	MASS(kg)
2965906	ANCHOR SCREW EXT TOOL M24	2.15
5405098	DYWIDAG SPANNER	2.10



Application - Water Bar Ties

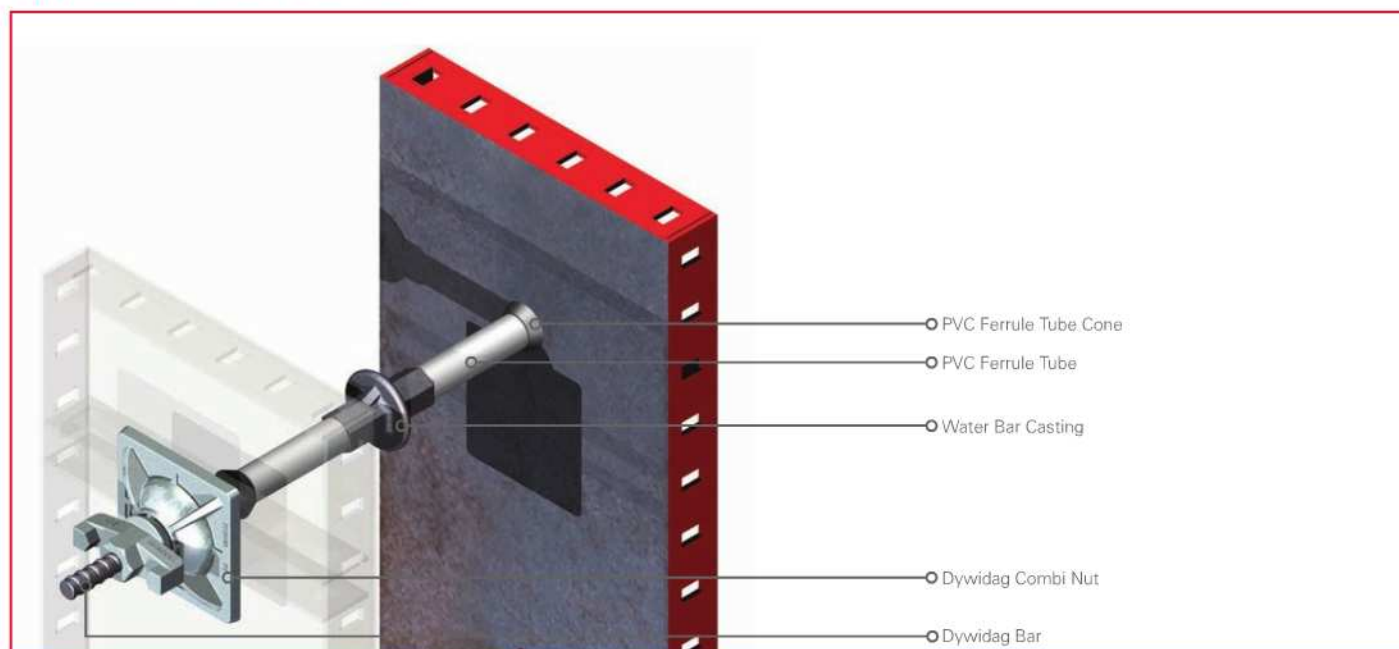

Coil Tie

Is used to tie panels on opposite sides of a concrete wall together.

CODE	DESCRIPTION	MASS(kg)
5821019	COIL TIE EXTENDED 12 X 525	0.36
5821017	COIL TIE EXTENDED 12 X 475	0.33
5821015	COIL TIE EXTENDED 12 X 425	0.31
5821013	COIL TIE EXTENDED 12 X 375	0.29
5821011	COIL TIE EXTENDED 12 X 325	0.26
5821009	COIL TIE EXTENDED 12 X 275	0.23
5821007	COIL TIE EXTENDED 12 X 225	0.21
5821005	COIL TIE EXTENDED 12 X 175	0.19
5821003	COIL TIE EXTENDED 12 X 125	0.16
5821001	COIL TIE EXTENDED 12 X 75	0.14



Coil Tie (With Water Bar)

Is used to provide a water tight seal within the concrete.

CODE	DESCRIPTION	MASS(kg)
5822019	COIL TIE EXT 12 X 525 (WATER-BAR)	0.40
5822017	COIL TIE EXT 12 X 475 (WATER-BAR)	0.37
5822015	COIL TIE EXT 12 X 425 (WATER-BAR)	0.35
5822013	COIL TIE EXT 12 X 375 (WATER-BAR)	0.33
5822011	COIL TIE EXT 12 X 325 (WATER-BAR)	0.30
5822009	COIL TIE EXT 12 X 275 (WATER-BAR)	0.27
5822007	COIL TIE EXT 12 X 225 (WATER-BAR)	0.25
5822005	COIL TIE EXT 12 X 175 (WATER-BAR)	0.23
5822003	COIL TIE EXT 12 X 125 (WATER-BAR)	0.20
5822001	COIL TIE EXT 12 X 75 (WATER-BAR)	0.18

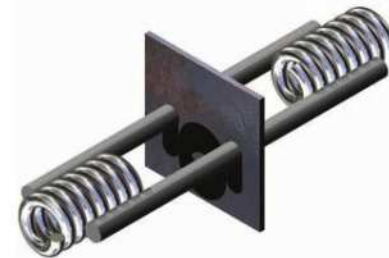

Coil Loop

Is cast into the concrete to provide an anchorage point.

CODE	DESCRIPTION	MASS(kg)
5810053	COIL LOOP 20 X 300	0.31
5810052	COIL LOOP 20 X 225	0.21
5810051	COIL LOOP 20 X 150	0.16
5805004	COIL LOOP 12 X 300	0.20
5805003	COIL LOOP 12 X 225	0.20
5805002	COIL LOOP 12 X 150	0.13
5805001	COIL LOOP 12 X 100	0.10



Coil Extension Cone

Is used to create a flush joint between the end of the tie and the panel face.

CODE	DESCRIPTION	MASS(kg)
5870631	COIL EXT CONE M12 X 38 (SQUARE)	0.02



Coil Washer Round

Is used to seat the coil extension cone into position.

CODE	DESCRIPTION	MASS(kg)
5870633	COIL WASHER ROUND 0.5mm	0.01
5870634	COIL WASHER ROUND 1mm	0.01



Coil Tie Bolt

Secures the Econo-Form Panel to the Tie.

CODE	DESCRIPTION	MASS(kg)
5845404	COIL TIE BOLT 12 X 125	0.14
5845405	COIL TIE BOLT 12 X 150	0.18



Coil Washer

Provides a stable bearing surface for the Coil Tie Bolt.

CODE	DESCRIPTION	MASS(kg)
5860611	COIL WASHER 100 X 100 X 6	0.40
5855602	COIL WASHER 80 X 80 X 6	0.20
5855601	COIL WASHER 50 X 50 X 6	0.10



Coil Cone Combination Extractor

The Coil Cone Extractor tool is used to recover plastic Coil Cones from concrete. Different dimensions on either end allow it to recover both cone sizes.

CODE	DESCRIPTION	MASS(kg)
5865630	COIL CONE COMB. EXTRACTOR	1.68

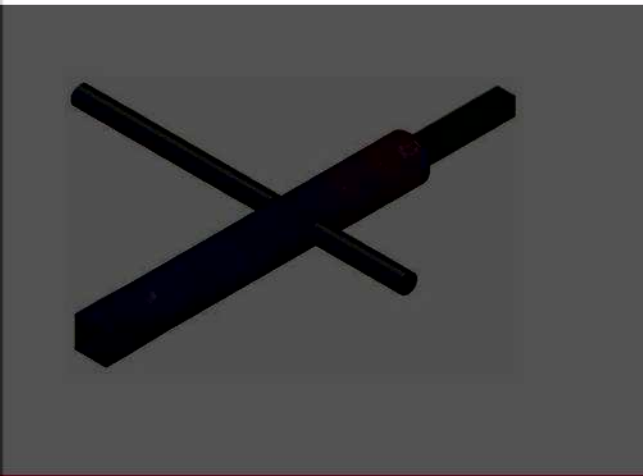

Application - Coil Ties

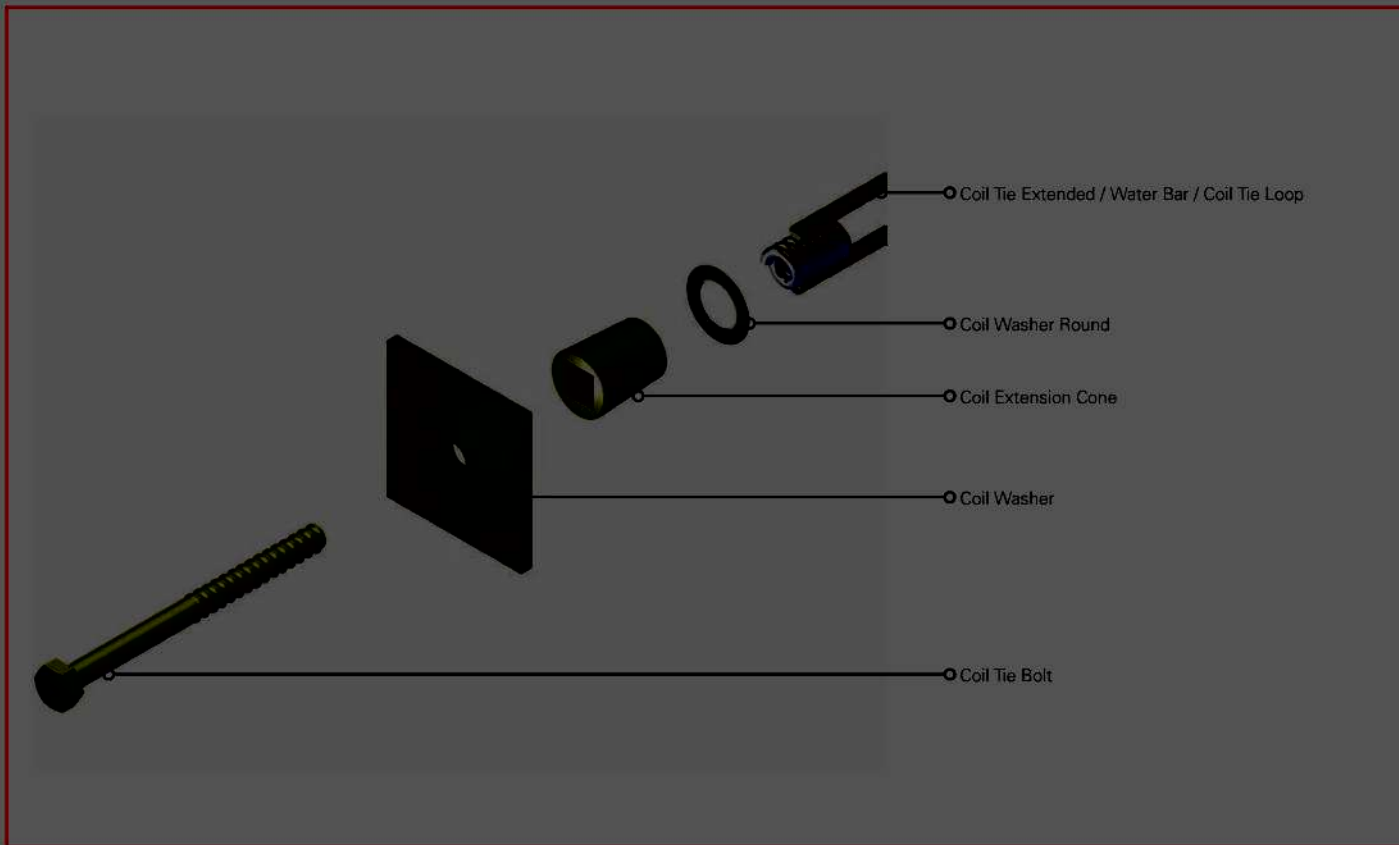

Form-Soldier

Form-Soldiers are placed behind the Econo-Form Panels when used in a gang-formed application. The ties are installed through the Form-Soldiers.

CODE	DESCRIPTION	MASS(kg)
5405009	FORM-SOLDIER 3600	82.49
5405008	FORM-SOLDIER 3300	76.21
5405007	FORM-SOLDIER 3000	69.92
5405006	FORM-SOLDIER 2700	63.64
5405005	FORM-SOLDIER 2400	57.35
5405004	FORM-SOLDIER 2100	51.07
5405003	FORM-SOLDIER 1800	44.78
5405002	FORM-SOLDIER 1500	38.50
5405001	FORM-SOLDIER 1200	32.21
5405012	FORM-SOLDIER 900 EXTENSION	26.20
5405011	FORM-SOLDIER 600 EXTENSION	20.39
5405010	FORM-SOLDIER 300 EXTENSION	14.12



Form Wall Bracket

The Form Wall Bracket holds the Form Support bracket in place. The Form Wall Bracket is bolted to the Anchor Screw which is cast into the concrete.

CODE	DESCRIPTION	MASS(kg)
5405025	FORM WALL BRACKET	4.50



Anchor Screw

The Anchor Screw is mainly used to secure the Form-Wall Bracket to the concrete wall.

CODE	DESCRIPTION	MASS(kg)
2965904	ANCHOR SCREW M36 X 432	4.00
2965903	ANCHOR SCREW M24 X 280	1.07
2965902	ANCHOR SCREW M20 X 197	0.94
2965901	ANCHOR SCREW M20 X 121	0.58



Extractor Tool

Is used to remove an Anchor Screw from the concrete.

CODE	DESCRIPTION	MASS(kg)
2965905	ANCHOR SCREW EXT TOOL M20	2.12
2965906	ANCHOR SCREW EXT TOOL M24	2.15
2965907	ANCHOR SCREW EXT TOOL M36	2.15

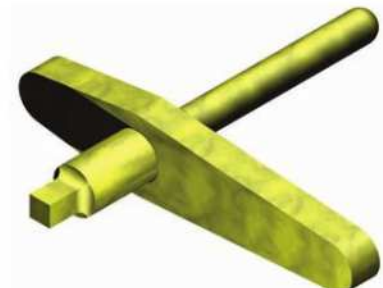

Form Support Bracket

The Form Support Bracket is placed onto the Form Wall Bracket and creates a safe working platform as well as a support platform for the Plumbing Bracket. The sleeve at the end of the Form Support Bracket locates a 48mmØ handrail stanchion.

CODE	DESCRIPTION	MASS(kg)
5405023	FORM SUPPORT BRACKET	25.74



Form Hanging Bracket

The Form Hanging Bracket is suspended from the Form Support Bracket and creates a working platform 3200mm below the Form Support Bracket.

CODE	DESCRIPTION	MASS(kg)
5405024	FORM HANGING BRACKET	23.90

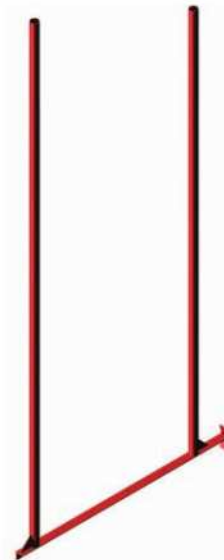

Form Access Bracket

The Form Access Bracket gets bolted to the back of the Form-Soldier to create a safe access platform 685mm wide. The sleeve at the end of the Form Access Bracket locates a 48mmØ handrail stanchion.

CODE	DESCRIPTION	MASS(kg)
5405021	FORM ACCESS BRACKET	7.46



Form Plumbing Bracket

The Form Plumbing Bracket is bolted to the lower end of the Form-Soldier and facilitates vertical alignment of the gang-formed Formwork.

CODE	DESCRIPTION	MASS(kg)
5405022	FORM PLUMBING BRACKET	19.78



Application - Climbing

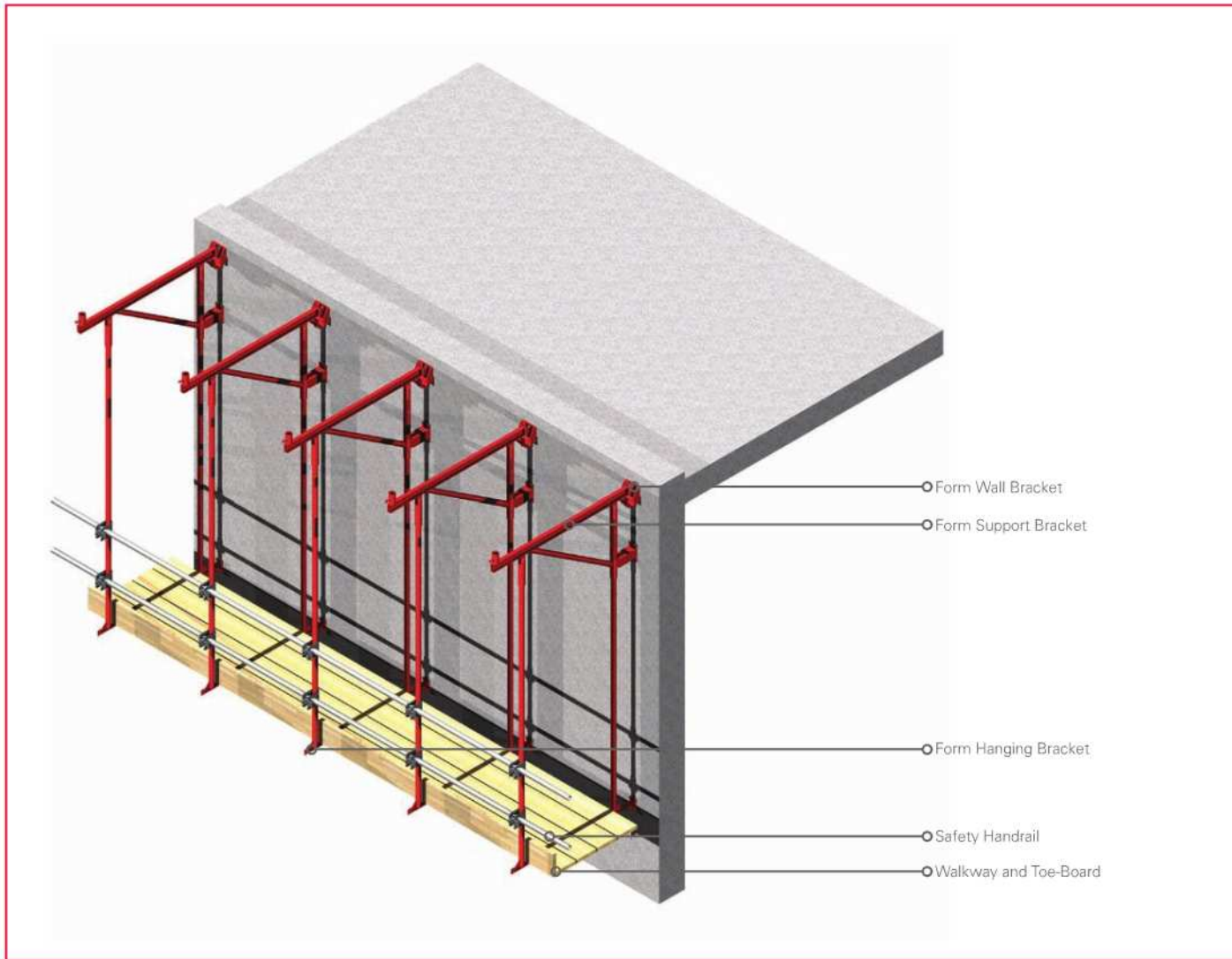

Application - Anchors



General Assembly

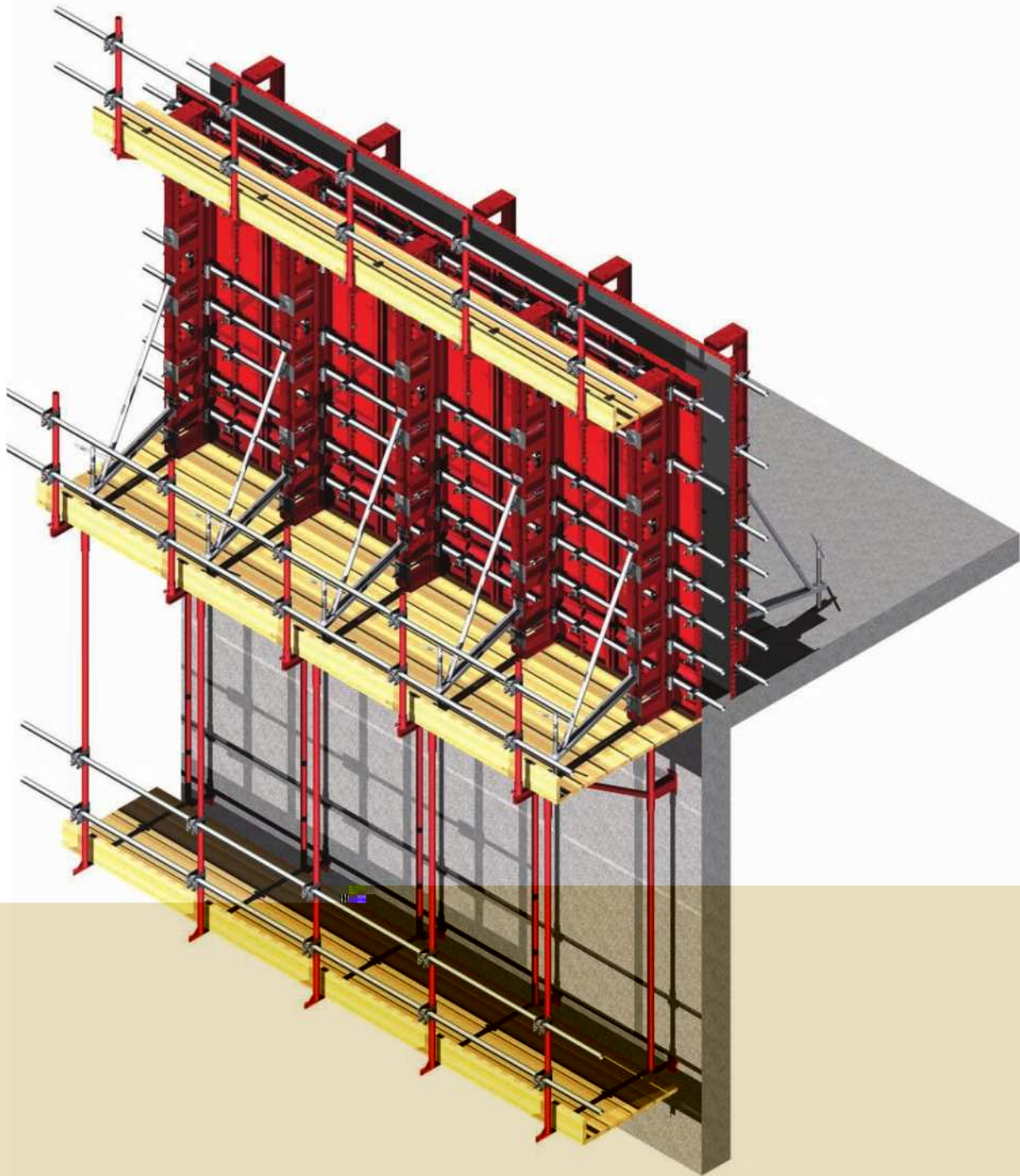

Form Bottom Plate

The Form Bottom Plate is used to prevent the Form-Soldier Panels from slipping off the end of the of the Form-Soldiers when lifting a gang-formed unit.

CODE	DESCRIPTION	MASS(kg)
5405082	FORM BOTTOM PLATE	2.40

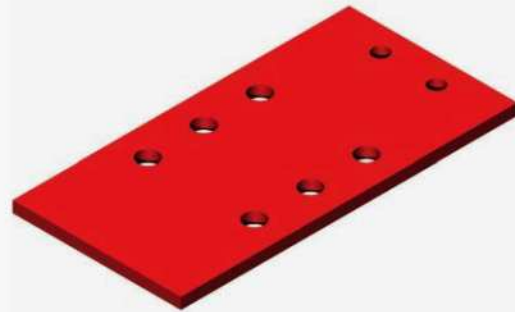

Form Lifting Hooks

The Form Lifting Hook is attached to the end of a Form-Soldier to create a safe lifting point.

CODE	DESCRIPTION	MASS(kg)
5405013	FORM LIFTING HOOK (PLATE)	3.72
5405081	FORM LIFTING HOOK (ROUND BAR)	1.05

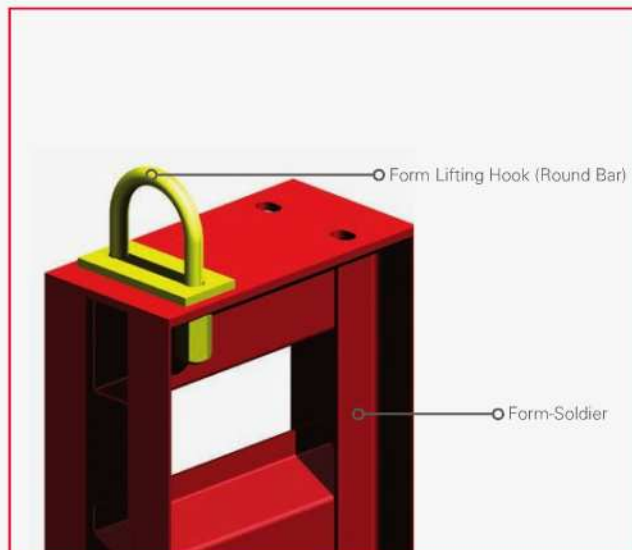
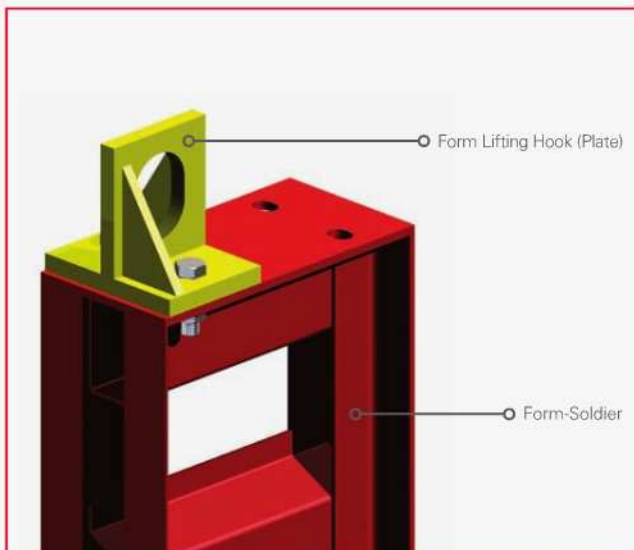

Form Channel Waler Clip

Form Channel Waler Clips are used to connect a 100mm x 50mm Channel Waler to the Form-Soldier face.

CODE	DESCRIPTION	MASS(kg)
5405043	FORM CHANNEL WALER CLIP	0.87



Form Tube Waler Clip

Form Tube Waler Clips are used to connect a scaffold tube to the Form-Soldier face.

CODE	DESCRIPTION	MASS(kg)
5405042	FORM TUBE WALER CLIP	0.60

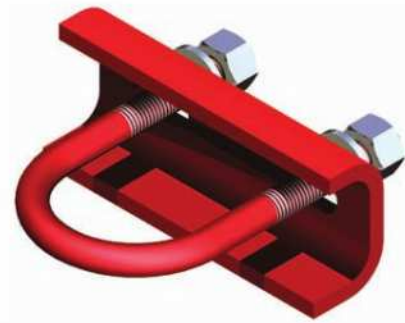

Form Timber Waler Clip

Form Timber Waler Clips are used to attached timber sections to the Form-Soldiers.

CODE	DESCRIPTION	MASS(kg)
5405044	FORM TIMBER WALER CLIP	0.54



Form Panel Clip

Form Panel Clips are used to connect the Econo-Form Panels to the Form-Soldier face.

CODE	DESCRIPTION	MASS(kg)
5405041	FORM PANEL CLIP	0.35



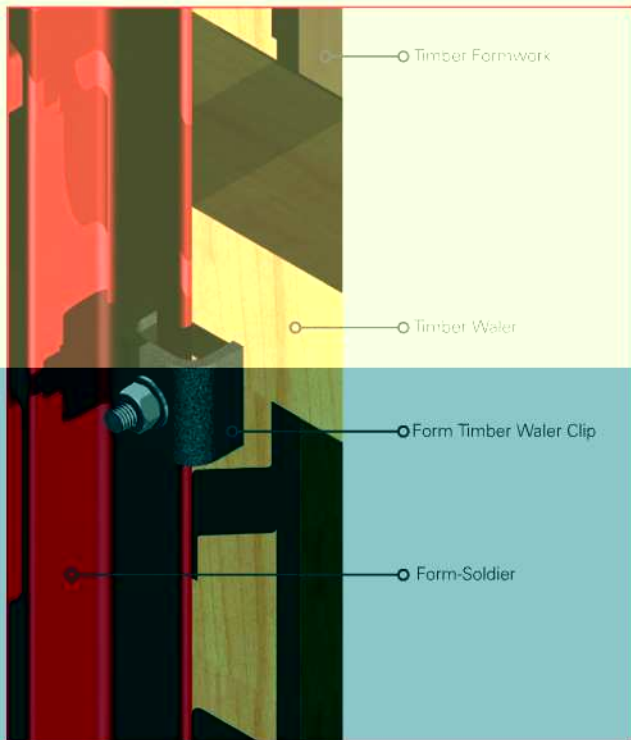
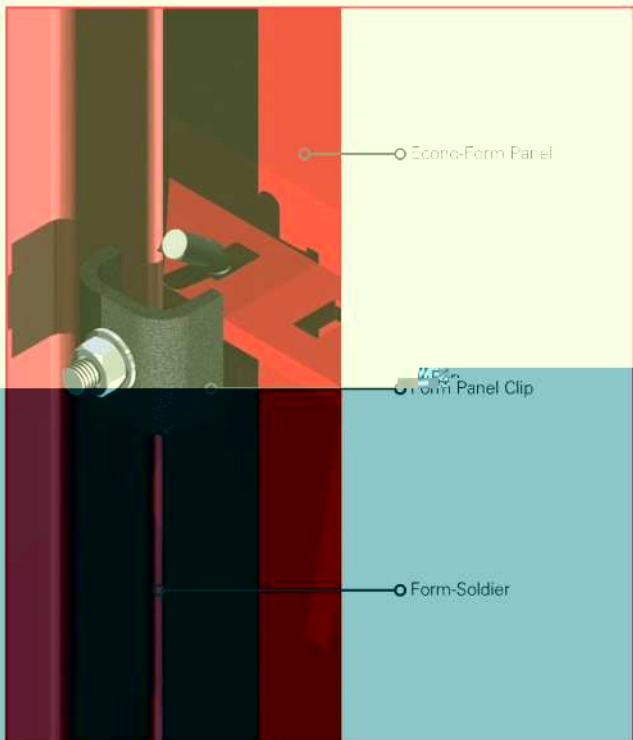
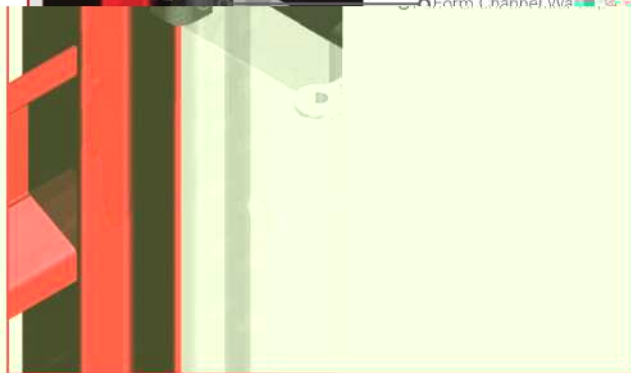
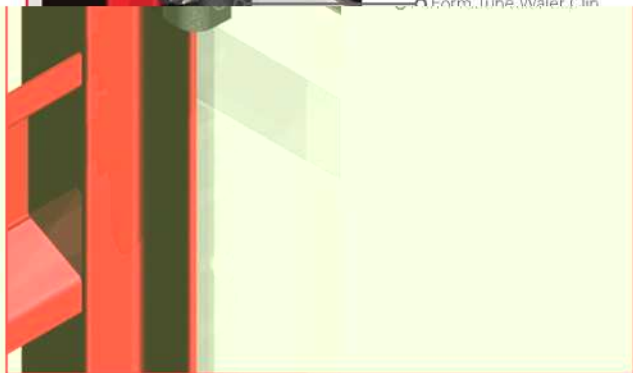
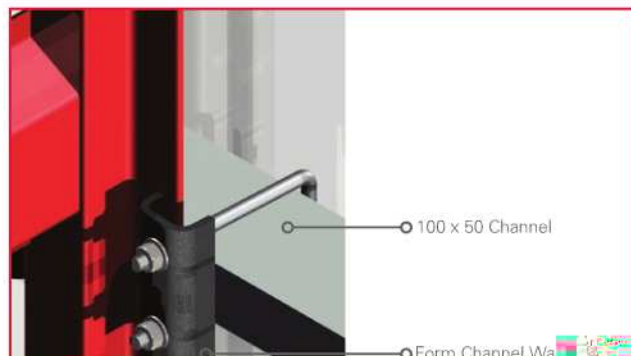

Contact Details

HEAD OFFICE

P.O. Box 669, Isando, 1600
181 Barbara Road, Elandsfontein
Tel 011 842-4000, Fax 011 842-4280

INLAND BRANCHES

BLOEMFONTEIN

P.O. Box 6610, Bloemfontein, 9300
22 Wilhelm Kotze Street, Oosseinde
Tel 051 432-5555/6, Fax 051 432-4477

JOHANNESBURG

P.O. Box 2884, Honeydew, 2040
40 Homestead Avenue, Kya Sands
Tel 011 708-2227, Fax 011 708-1159

JOHANNESBURG EAST

P.O. Box 26994, Boksburg, 1462
181 Barbara Road, Gate 3, Elandsfontein
Tel 011 842-4215, Fax 011 842-4111

NELSPRUIT

P.O. Box 4485, Nelspruit, 1200
Erf 379, Rocky Drift
Tel (013) 758-1036, Fax (013) 758-1063

POLOKWANE

P.O. Box 3979, Pietersburg, 0700
Hospital Street Extension
Tel 015 297-1550/1, Fax 015 297-4193

PRETORIA

P.O. Box 4466, Pretoria, 0001
Park Lane Ave, Highway Business Park,
Rooihuiskraal
Tel (012) 621-9900, Fax (012) 621-9931

RUSTENBURG

P.O. Box 6996, Rustenburg, 0300
3 Ferro Street, Zinniville
Tel 014 538-2540/3, Fax 014 538-0087

SECUNDA

P.O. Box 3871, Secunda, 2302
No.1 Corner Wilton Nkwayi and Bram
Fischer Rd, Winkelhaak, Evander
Tel 017 632-4153, Fax 017 632-4234

VEREENIGING

P.O. Box 1010, Vereeniging, 1930
Cnr Telford & Van Riebeeck Ave,
Duncanville
Tel 016 455-1611/2, Fax 016 455-1566

WITBANK

P.O. Box 3869, Witbank, 1035
2 Kromhout Street, Witbank
Tel 013 690-2833, Fax 013 656-3713

KWAZULU NATAL BRANCHES

KZN REGIONAL OFFICE

P.O. Box 33, New Germany, 3620
149 Shepstone Road, New Germany
Tel 031 705-1112/3, Fax 031 705-4423

DURBAN

P.O. Box 1572, New Germany, 3620
72 Gillits Road, Westmead
Tel (031) 792-5080/1, Fax (031) 700-9181

DURBAN SOUTH

P.O. Box 485, Umbogintwini, 4120
16 Stroude Place, Isipingo
Tel 031 902-2677, Fax 031 902-2771

MARGATE

P.O. Box 1171, Margate, 4275
Industrial Road, Margate
Tel 039 317-1708/9, Fax 039 317-4073

NEWCASTLE

P.O. Box 906, Newcastle, 2940
22 Schonland Street, Industrial Sites
Tel (034) 375-7697, Fax (034) 375-6935

PIETERMARITZBURG

P.O. Box 21946, Mayors Walk, 3208
Market Road Ext, Mkondeni
Tel 033 346-1767/9, Fax 033 346-1753

RICHARDS BAY

P.O. Box 1333, Richards Bay, 3900
111 Allumina Alley, Alton Industrial Area
Tel 035 751-1140, Fax 035 751-1094

BALLITO

P.O. Box 715, Umhlali, 4390
Labora Terra Industrial Park,
Shakas Rock Rd, Ballito, 4381
Tel 032 947-9430, Fax 032 947-0583

CAPE BRANCHES

CAPE TOWN

P.O. Box 37068, Chempet, 7441
6 Drill Ave, Montague Gardens, 7441
Tel 021 551-3507, Fax 021 551-1743

EAST LONDON

P.O. Box 2734, Beacon Bay, 5205
5 Ray Craib Crescent, Beacon Bay
Tel 043 748-2558, Fax 043 748-3691

MOSSEL BAY

P.O. Box 218, Hartenbos, 6520
12 Voorbaai Crescent, Mossel Bay
Tel 044 695-0294, Fax 044 695-1040

PORT ELIZABETH

P.O. Box 2112, North End, 6056
4 Kendle Street, Neave Industrial Area
Tel 041 453-2317, Fax 041 453-2524

STRAND

P.O. Box 1654, Somerset West, 7129
Chilwan Crescent, Helderberg Industrial
Area Park, Strand
Tel 021 845-4090, Fax 021 845-4091

FORM-SURE – CONTRACTING DIVISION

JOHANNESBURG

P.O. Box 2884, Honeydew, 2040
18 Grader Rd, Spartan, Kempton Park
Tel 011 974-8019, Fax 011 974-4476

CAPE TOWN

P.O. Box 37113, Chempet, 7442
27 Chain Ave, Montague Gardens, 7441
Tel 021 552-8377, Fax 021 552-8376

INTERNATIONAL BRANCHES

MAURITIUS

P.O. Box 748, Bell Village,
Port Louis Western
Plaine Lauzun Industrial Estate
Tel 00230 211-0391 & 210-2521
Fax 00230 211-0392

NAMIBIA

Hire, Sales & Service cc
P.O. Box 20286, Windhoek 9000
5 Nickel Street, Prosperitas
Tel 0026461 23-3693
Fax 0026461 23-3272

CHILE

Cerro Portezuelo 9801,
Parque Industrial Portezuelo,
Qulicura, Santiago de Chile
Tel 00562 738 5019
Fax: 00562 738 6521

0800 20 50 29

1/5

011

Technical Advice Centre 0800 20 50 29 / (011) 842 4280

0800, Fax (011) 842 4280

WYNCE AFRICA / HILFSDIENST: PO Box 609, Isando, 1600, 181 Barbara Road, Handfontein. Tel (011) 842 4280

mscaff.com

www.fort